

F-250 NO-SLIP LOCKING PLATES  
FOUR REQUIRED

(CAMBER ADJUSTMENT CAM REPLACEMENT FOR  
TUF-COUNTRY DROPPED AXLE PIVOTS)

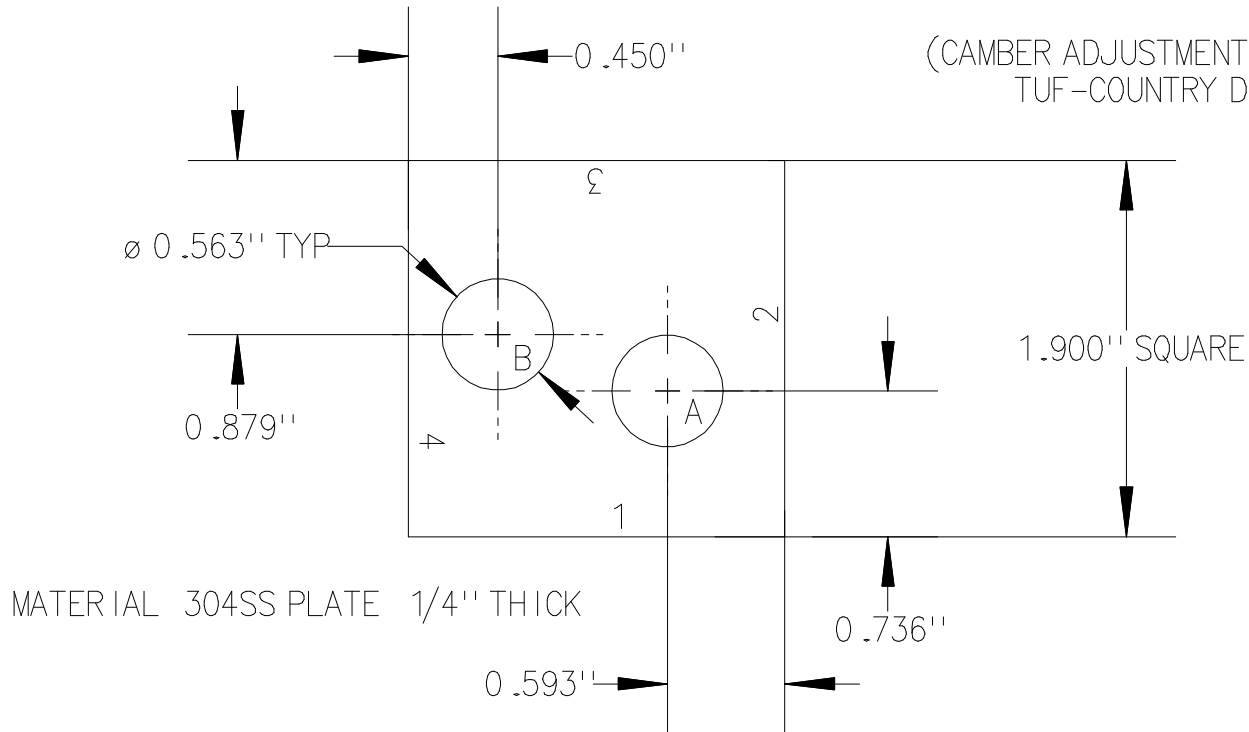

MATERIAL 304SS PLATE 1/4" THICK

ADJUSTMENT CHART

BOTTOM SIDE	BOLT IN HOLE	RELATIVE CAMBER
4	B	0
2	A	0.21 DEG
1	A	0.43 DEG
3	B	0.64 DEG
1	B	0.86 DEG
3	A	1.07 DEG
2	B	1.50 DEG

NOTES

- 1) STAMP IDENTIFICATION FOR ALL EDGES AND BOTH HOLES INTO BOTH SIDES OF PLATE.
- 2) BE SURE TO SET FRONT AND REAR PLATE TO SAME SETTING FOR EACH AXLE. (PIVOT BOLT TO BE LEVEL) TWO AXLES MAY BE SET TO DIFFERENT SETTINGS, HOWEVER.
- 3) BE SURE LOCK PLATES ARE WELL SEATED BETWEEN STOPS ON PIVOT BRACKET BEFORE TIGHTENING BOLTS.
- 4) ROTATE PASSENGER SIDE DRIVE-AXLE TO BE SURE ADEQUATE CLEARANCE EXISTS. FLIP INNER LOCKING PLATES OR SHORTEN BOLTS AS REQUIRED TO ASSURE CLEARANCE.